

THE DESIGN OF PRESSING EQUIPMENT FOR BANANA FRUIT

M.C. Tri Atmodjo #¹

BPPT Researcher

atmojo_b2tp@yahoo.com

ABSTRACT

The Banana plants in Indonesia can grow well both high and lowland, from the temperate wet and dry climate. In addition to the consumption of fresh banana in Indonesia a few cultivars are also widely used as industrial raw material chips, "*sale pisang*" and banana flour. Many craftsmen who developed food banana in the form of sale due to ease in the manufacturing process. Making banana sale in the domestic industrial scale is still mostly done by hand which is only capable of producing 20 kg / hour in the form of processed banana fruit in banana sale. So many craftsmen maker banana sale household scale industries can not buy banana in large numbers. In the manufacture of sale of banana is done manually are still many shortcomings, which measure the thickness of the sale of banana produced uneven.

In general, pressing machine banana sale is a tool that changes the shape of banana from thick to thin size. By utilizing the roll rotation that drives the conveyor belt top and conveyor belt bottom of the moving direction. In this study is designed pressing sale banana tool driven electric motor with power 2 hp 1 phase with a speed of 1400 rpm. With a shaft diameter of 25 mm, the size of the pegs 10x22 mm with a depth of 5 mm. Gear is used in this reduction type where a large number of gear as much as 115 teeth, gear motor driver as much as 9 teeth and roll gear driver as much as 15 teeth. Bearings used in the manufacture of this pressing banana sale tool is bearing 6305 ZZ C3 P6 type.

Resulting of test manufacturing pressing banana sale tool conducted showed that the pressing machine capable flattens banana sale with an average size of 10.16 cm in length banana sale, with 3.3 cm and 0.36 cm thick with a capacity of 90 Kg/hour or in day (7 hour) machine capable of pressing flattens banana sale much as 630 Kg/day.

Key words : Banana plants, pressing, machine design, Sale pisang.

I. INTRODUCTION

1.1 Background

The Crop of Banana in Indonesia can grow well in lowland which have wet climate and also have dry climate. Its fruit present every time and not depend to season, its spreading area almost in all of Indonesia. Banana represent one of the pre-eminent fruit commodity in Indonesia. Banana crop production always occupy first position. Banana production most harvested from people field. Beside for fresh

consumption, some banana variety in Indonesia are also exploited with industry of banana for example industry of banana chips, banana flour and fermented banana (FB) or Banana Sale (BS).. Banana containing many mineral and vitamin of essential which is very good for health. Development of banana commodity in Indonesia is fair enough, good to fulfilling request of domestic market and also world market. With amount of resident more than 200 million (BPS, 2010) in Indonesia, request of banana in domestic market not only limited to fresh banana, quite a few request in the form of processed banana (flaky, FB, banana pasta). The Main Competitor state for Indonesia in exporting banana is Ekuador, Philipina, and Colombia. Province which represent one of the producer of biggest banana is Sumatra area with amount of banana production equal to 349,928 ton / year (Suyanti, 2008). Banana type which found many in area is banana type of ambon, raja sere, muli, kapas, lilin and mas.

With amount of high banana production from all farmer of banana many industrial house of making of banana sale sometimes not ready to buy banana of farmer in number which many that thing is because of is tardy of him process workmanship of banana sale. Tardy [of] him of [is] process of banana sale because of worker of maker of banana sale still a lot use appliance manually or in making of banana sale still use hand for pressing of banana sale. By pressing process of banana sale have weakness that is low productivity level with result 20 kg/hour. This matter push researcher to design an appliance for pressing of banana sale with expected home industry scale later this appliance can quicker the process of banana sale so that can increase product in making of banana sale.

1.2. objectives

1. To design appliance for pressing banana sale or *Sale Pisang* with capacities 90 Kg /hour,
2. To increase the production of banana sale in home industry.

II. MATERIALS AND METHOD

II.1 Type of research

Research type taken is design and making prototype of banana sale pressing machine and analysis the number of banana sale pressed by the pressing machine.

II.2 Time and research place

This research was conducted on 25 of April to 1st of August 2010 in workshop of countryside of Selapan, District Of Candipuro South of Lampung.

II.3 Variables

1. Tied Variable

Tied variable at making of appliance of this banana sale is machine capacities in making banana sale (“Sale pisang”).

2. Free Variable

Free variable at making of appliance of this banana sale is energy and rotation yielded by activator motor

3. Controlling Variable

Variable in control [at] making of appliance of this banana sale [is] appliance form pressing of banana sale and raw material making of banana sale

4. Step of research

Research step in making of machine pengepres of this banana sale divided to become some phase among others [done/conducted] activity step before designing pressing appliance of banana sale, ready [of] materials and appliance to make pressing machine of banana sale, data analysis and method intake of data.

5. Bibliography Study

That is by studying and taking considerations of literatures related to problem of scheme, good in the form of book, media a period of/to, and source of from internet

6. Field Study

Accurate directly process pengepresan of [done/conducted] banana sale by manual or [do] not use machine.

7. Quantitative Analysis

In this analysis of data elaborated in the form of clear numbers as according to usefulness, so that can give meaning to data. To get capacities of pressing machine of banana sale used by equation

$$Q = \frac{M}{t} (kg / dtk)$$

Where

Q = Capacities of machine pengepres of banana sale (kg / sec)

M = Weight of banana sale to be processing (kg)

t = Time used in pressing of banana sale (sec.)

III. RESULT AND DISCUSSION

In designing of pressing appliance of banana sale used equation of energy and torque (Sularso, 1997), to design axis, lanching and pad to be used. Electromotor which is used in scheme of pressing appliance of this banana sale is electromotor with power 2 HP , used 220 volt of voltage and 1400 rpm.

The gear system in this research showed in table 1.

Table 1. Gear system

No	Name of gear	Diameter	Weight	Number of tooth in gear	Number of gear
1	Gear of main motor	3 cm	0,2 kg	9	1
2	Main gear	30 cm	2 kg	115	1
3	Little gear	6,5 cm	0,3 kg	15	4

1. Operation Motor

By the data on table 1, the force available on each gear calculated by the equations below respectively.

$$F_1 = (0,2kg) \times (9,81m/sec^2) = 1,96N$$

$$F_2 = (2kg) \times (9,81m/sec^2) = 19,62N$$

$$F_3 = (0,3kg) \times (9,81m/sec^2) = 2,94N$$

The torque as the result from force of all gear calculated as following.

$$T = F_1 \times r_1 + F_2 \times r_2 + F_3 \times r_3$$

$$T = (1,96 \times 0,015) + (19,62 \times 0,15) + (2,94 \times 0,0325 \times 4)$$

$$= 0,029 + 2,943 + 0,382$$

$$= 3,354kg.m$$

$$= 3354kg.mm$$

The power from the motor calculated as following.

$$P = \frac{2 \times \pi \times n \times T}{60}$$

$$= \frac{2 \times 3,14 \times 1400 \times 3,354}{60}$$

$$= 491,47Watt$$

$$= 0,491KW$$

2. The Shaft

The plan of Power with corection factor 1,2 as following.

$$\begin{aligned}
 P_d &= f_c \cdot xp \\
 &= 1,2 \times 1,492 \\
 &= 1,790 \text{ KW}
 \end{aligned}$$

The shear stress as following.

$$\begin{aligned}
 \tau_a &= \sigma_B / (sf_1 \cdot xsf_2) \\
 &= 58 / (6,0 \times 3,0) \\
 &= 3,222
 \end{aligned}$$

The Diameter of shaft calculated as following

$$\begin{aligned}
 d_s &= \left[\frac{5,1}{\tau_a} \cdot xk_t \cdot xc_b \cdot xT \right]^{1/3} \\
 &= \left[\frac{5,1}{3,222} \cdot x1,5 \cdot x1,7 \cdot x3354 \right]^{1/3} \\
 &= [1,582 \cdot x1,5 \cdot x1,7 \cdot x3354]^{1/3} \\
 &= 23,83 \text{ mm}
 \end{aligned}$$

According to table number 4 so 25 mm diameter with 600 mm long is suitable for this shaft.

3. The dowel

The tangensial force calculated as following.

$$\begin{aligned}
 F &= \frac{T}{(d_s/2)} \\
 &= \frac{3354}{(25/2)} \\
 &= \frac{3354}{12,5} = 268,32 \text{ kg}
 \end{aligned}$$

The shear stress calculated as following.

$$\begin{aligned}
 \tau_k &= \frac{F}{b \cdot l} \\
 3,2 &= \frac{268,32}{b \cdot l}
 \end{aligned}$$

By b value is 10 mm and so :

$$b \cdot l = \frac{268,32}{3,2}$$

$$b \cdot l = 83,85$$

$$l = \frac{83,85}{10} = 8,38 \text{ mm}$$

The allowable shear stress is 3.2 there fare :

$$\tau_{ka} \geq \frac{F}{b \cdot l_1}$$

$$3,2 \geq \frac{268,32}{10 \cdot 8,38}$$

$$3,2 \geq 3,2$$

The allowable pressure in the dowel for small size of diameter is 8 kg/mm² (Sularso, 1997) so :

$$p = \frac{F}{l \cdot (t_1 + t_2)}$$

$$8 = \frac{268,32}{8,38 \cdot t_1}$$

$$t_1 = \frac{268,32}{8,38 \cdot 8}$$

$$t_1 = \frac{268,32}{67,04} = 4 \text{ mm}$$

And then :

$$p_a \geq \frac{F}{l \cdot (t_1 + t_2)}$$

$$8 \geq \frac{268,32}{8,34 \cdot 4}$$

$$8 \geq \frac{268,32}{33,52}$$

$$8 \geq 8$$

By table number 5 is got that the dimension of the dowel is width b 10 mm, long l 22 mm and dept t₁ 5 mm respectively

4. Ball bearing

The ball bearing used is. 6305 ZZ C3 P6 (sularso, 1997) 6 expressing single line ball pad [of] path in 3 abbreviation from 03, where 3 external diameter showe 52 mm for the diameter of hole 25 mm.

05 meaning 05 x 5 = 25 mm, hole diameter

ZZ mean bersil 2
 C3 [is] diffuseness of C3
 P6 mean correctness class:

5. Gear

The Gear at scheme of pressing machine of this banana sale is diametrical gear, where for used by small gear of motor gear with amount of tooth 15 big gear and with amount of tooth counted 115.

6. Transmission chain

Transmission chain which [is] used [at] scheme of pressing appliance of this banana sale is enchaining type motor of F 10, with specification of from enchaining activator there are at Tables 7:

Tables 2. Specification of chain

Name of part	Size
Number of chain	40 (one set)
Distance (P)	12,70 mm
Diameter of rol (K)	7,94 mm
Wide of rol (W)	7,95 mm
Diameter of pen chain (D)	3,97 mm
Distance between axis	200 mm

7. The Rotation of Axis

$$i = \frac{z_1}{z_2}$$

$$= \frac{9}{115} = 0,078$$

where:

$$n_1 = 1400 \times 0,078$$

$$= 109,2 \text{ rpm}$$

$$= 1,82 \text{ rps}$$

8. Belt Conveyor

This belt conveyor made from ruber to keep banana sale to be clean.

Table 3. Belt Conveyor (upper part)

Material	Length	Wide	Thickness
Made of ruber	136 cm	30 cm	0,5 cm

Tabel 4. Belt conveyor (lower part)

Material	Length	Wide	Thickness
Made of ruber	184 cm	30 cm	0,5 cm

9. Spacer of thickness

Spacer of thickness would arrange thick attenuate banana sale at the pressing time. This spacer attached at roll so that apart between roll can change according to the size wanted. This component is made from axis which is fill into roll and then bound to use bolt to framework.

10. The Dimension of Banana Sale pressing machine

The dimension of Banana Sale pressing machine presented in figure 1.

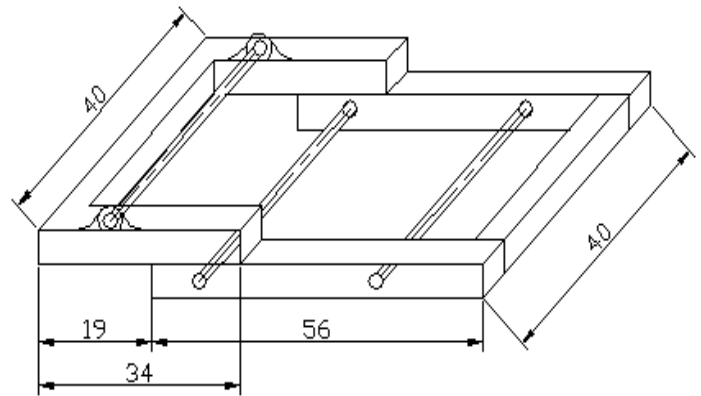

Fig 1. The Top part of Frame

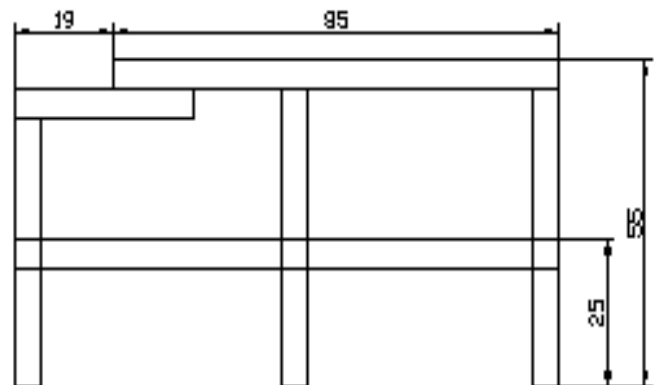

Fig 2. The Bottom part of frame

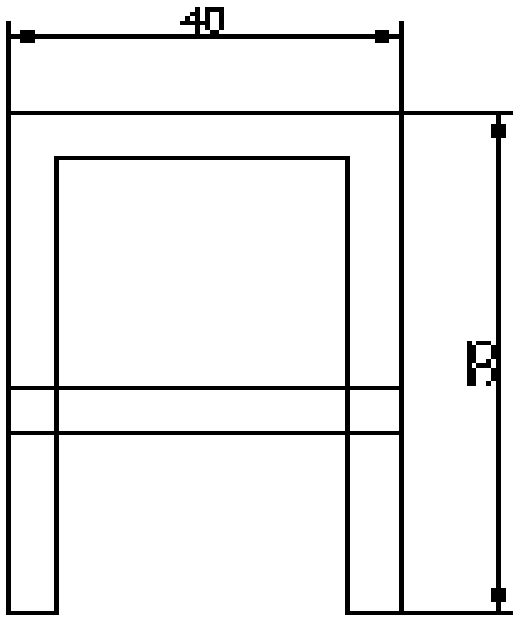

Fig 3. The Front view of frame

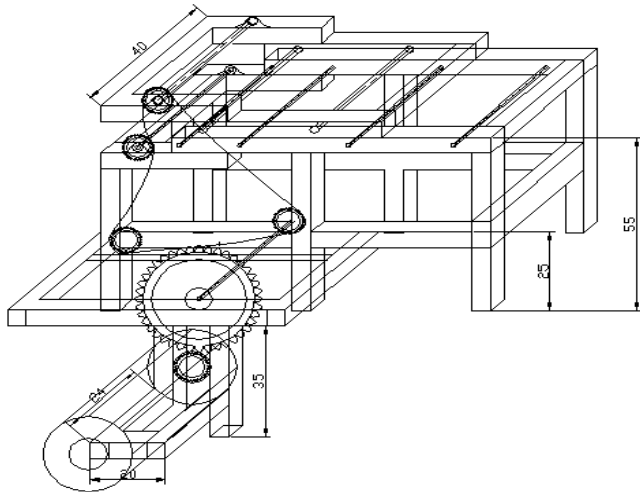

Fig 4. The Pressing Machine of banana sale

Tabel 6. The dimension of banana mas after processing.

No	length	width	thickness
1	10 cm	3,3 cm	0,4 cm
2	9,8 cm	3 cm	0,4 cm
3	10,2 cm	3,5 cm	0,4 cm
4	10,3 cm	3,3 cm	0,4 cm
5	10,5 cm	3,4 cm	0,4 cm
Mean	10,16 cm	3,3 cm	0,4 cm

Table 7. The result of trial run

No	Weight of banana	Pressing time (sec.)
1	1 kg	40,09
2	1 kg	39,82
3	1 kg	40,08
4	1 kg	40,10
5	1 kg	39,91
Mean	1 kg	40

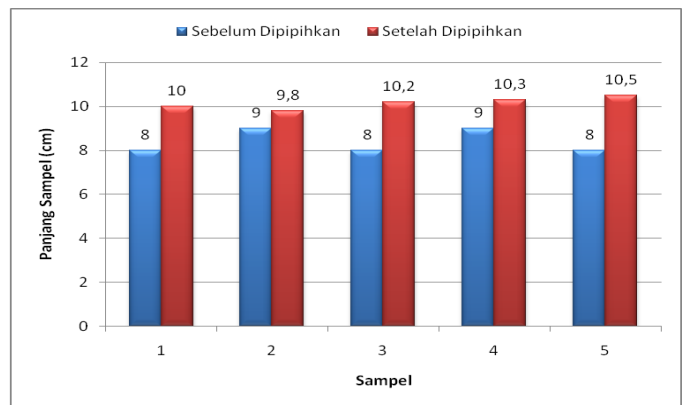

Fig 5 . Length of banana before pressing (blue) and after pressing (red)

11. Result of trial run

Table 5. The dimension of banana mas before processing.

No	length	width	thickness
1	8 cm	2,5 cm	1,5 cm
2	9 cm	2,7 cm	1,5 cm
3	8 cm	2,5 cm	1,2 cm
4	9 cm	2,5 cm	1,2 cm
5	8 cm	2,2 cm	1 cm
Mean	8,4 cm	2,48 cm	1,28 cm

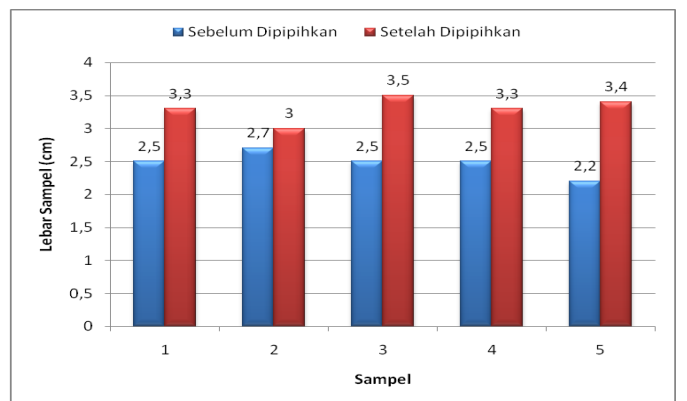

Fig. 6. Width of banana before pressing (blue) and after pressing (red)

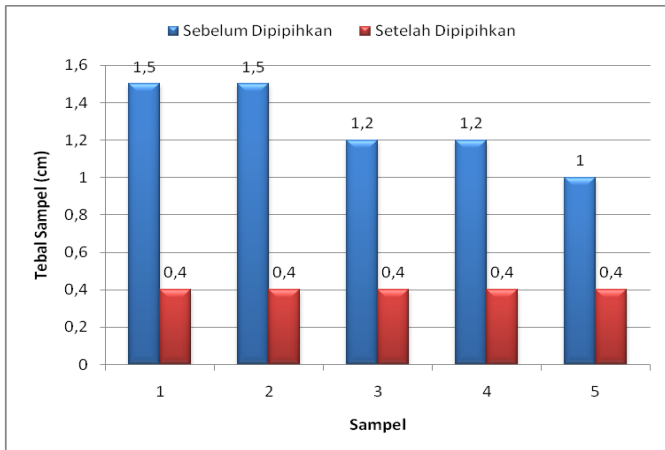

Fig. 7. The tickness of banana before pressing (blue) and after pressing (red)

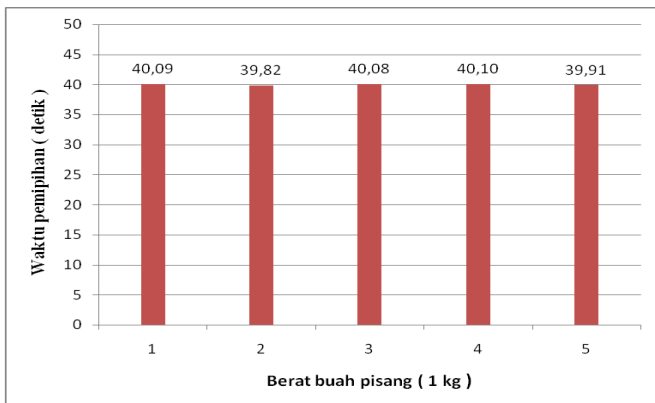

Fig. 8. Time of pressing (second)

12. Capacity of pressing machine

$$Q = \frac{M}{t}$$

$$= \frac{1kg}{40sec} = 0,025kg / sec$$

or

$$Q = (0,025kg / sec) \times (3600 sec)$$

$$= 90kg / hour$$

or

$$Q = (90kg / hour) \times (7hour / day)$$

$$= 630kg / day$$

Capacity of pressing banana sale by worker with hand only 140 kg/day and not so clean as by pressing machine respectively.

IV. CONCLUSION

1. With result of conducting the examination showed that the capacities of pressing machine in making banana sale can produce 90 kg /hour or in one day (7 hour/day] yielding 630 kg / day
2. Result of examination of showed that pressing machine of banana sale can press with length 10,5 cm, wide 3,5 cm and thick 0,4 cm.
3. The design of this pressing machine of this banana sale use equation of Sularso (1997) to determine axis diameter, ball bearing and dowel .The type ball bearing is 6305 ZZ C3 P6, axis diameter 25 mm and wide of dowel of equal to 10 mm, with length equal to 22 mm and deepness of dowel equal to 5 mm.

V. REFERENCE

- Budiman, A and Bambang Priambodo., 1994. *Elemen mesin Edisi kedua jilid I*.Erlangga, Jakarta
- Candra, H., 2001. *AutoCAD 2002 untuk pemula*. Alex Media Komputindo, Jakarta.
- Juanda T., 2002. *Konveyor Sabuk dan Peralatan Pendukung*. PT. Junto Engineering, Bandung.
- Malahayati., 2008, *Pedoman Penulisan Proposal, Tugas Akhir (skripsi) Dan Laporan Kerja Praktek*. Universitas Malahayati, Bandar Lampung.
- Petruzella, F.D., 2007. *Elektronik Industri*. Andi, Yogyakarta.
- Rohyana, S., 1999. *Perhitungan Kontruksi Mesin*. Amirco, Bandung.
- Rusmadi, D., 1991. *Aneka Hoby Elektronika*. Pionir jaya, Bandung.
- Shigley, J and Larry D., Mitchel., Gandi harahap., 1995. *Perancangan Teknik Mesin Edisi Keempat Jilid 2*. Erlangga. Jakarta.
- Sukrisno, U., 1983. *Bagian-bagian Mesin dan Merencana*. Erlangga, Jakarta.
- Sularso dan Kiokatsu S., 1997. *Dasar Perencanaan dan Pemilihan Elemen Mesin*. Pradnya paramitha, Jakarta.
- Suyanti., 2008. *Pisang budidaya, pengolahan, dan prospek pasar*. Penerbit Swadaya, Jakarta.