

ISSN : 2301-6590



# Proceedings ICETD 2012

The First International Conference in  
Engineering and Technology Development



**Universitas Bandar Lampung**  
**20 - 21, June 2012**  
**Lampung, Indonesia**



## PREFACE

The activities of the International Conference is in line and very appropriate with the vision and mission of the UBL to promote training and education as well as research in these areas.

On behalf of the First International Conference of Engineering and Technology Development (ICETD 2012) organizing committee; we are very pleased with the very good responses especially from the keynote speakers and from the participants. It is noteworthy to point out that about 45 technical papers were received for this conference

The participants of conference come from many well known universities, among others: Universitas Bandar Lampung, International Islamic University Malaysia, University Malaysia Trengganu, Nanyang Technological University, Curtin University of Technology Australia, University Putra Malaysia, Jamal Mohamed College India, ITB, Mercu Buana University, National University Malaysia, Surya Institute Jakarta, Diponegoro University, Unila, Universitas Malahayati, University Pelita Harapan, STIMIK Kristen Newmann, BPPT Lampung, Nurtanio University Bandung, STIMIK Tarakanita, University Sultan Ageng Tirtayasa, and Pelita Bangsa.

I would like to express my deepest gratitude to the International Advisory Board members, sponsors and also welcome to all keynote speakers and all participants. I am also grateful to all organizing committee and all of the reviewers which contribute to the high standard of the conference. Also I would like to express my deepest gratitude to the Rector which give us endless support to these activities, such that the conference can be administrated on time.

Bandar Lampung, 20 Juni 2012

**Mustofa Usman, Ph.D**  
**ICETD Chairman**

**PROCEEDINGS**  
**The First International Conference in**  
**Engineering and Technology Development**  
**(ICETD 2012)**

**UNIVERSITAS BANDAR LAMPUNG**  
Bandar Lampung, Indonesia  
June, 20-21 2012

**Sterring Commite**

**Chairman**

Mustofa Usman

**Co-Chairman**

Marzuki

**Technical Committee**

Ahmad Cucus

Agus Sukoco

Dina Ika Wahyuningsih

**Treasure**

Maria Shusanti Febrianti

**Committee Member**

Indyah Kumoro

Fritz Akhmad Nuzir

Baginda Simaimban

Berry Salatar

Harpain

Yuthsi Aprilinda

Usman Rizal

Andala Rama P. Barusman

Yanuar Dwi Prasetyo

**International Advisory Board**

Ahmad F. Ismail, Malaysia

Hon Wei Leong, Singapore

Mustofa Usman, Indonesia

Imad Khamis, USA

Moses L. Singih, Indonesia

Y. M. Barusman, Indonesia

Andreas Dress, Germany

Rozlan Alias, Malaysia

Faiz A.M. Elfaki, Malaysia

Rudi Irawan, Indonesia

Warsono, Indonesia

Gusri Ibrahim, Indonesia

Raihan Othman, Malaysia

Jamal I Daoud, Malaysia

Zeng Bing Zen, China

Riza Muhida, Indonesia

Tjin Swee Chuan, Singapore

Heri Riyanto, Indonesia

Khomsahrial R, Indonesia

Agus Wahyudi, Indonesia

Rony Purba, Indonesia

Lilies Widodojoko, Indonesia

Alex Tribuana S, Indonesia

## **Organizing Committee**

### **Chair Person**

Prof. DR. Khomsahrial Romli, M.Si

### **Vice Chair Person**

Drs. Harpain, M.A.T., M.M

### **Secretary**

Fritz Akhmad Nuzir, S.T., M.A  
Ahmad Cucus, S.Kom., M.Kom

### **Treasure**

Dian Agustina, S.E

### **Special Events**

DR. Zulfi Diane Zaini, SH., MH  
DR. Baginda Simaibang, M.Ed  
Zainab Ompu Jainah, SH., MH  
DR. Alex Tribuana S., ST., MM  
Erlangga, S.Kom

### **Recepcionist**

Berry Salatar, A.Md  
Yanuar Dwi Prasetyo, S.Pd.I., M.A  
Siti Rahma Wati, S.E  
Ardiansyah, ST., MT  
Sofie Islamia Ishar, S.T., M.T  
Taqwan Thamrin, S.T., M.Sc

### **Transportation and Acomodation**

Irawati, SE  
Usman Rizal, S.T., MMSi  
Hendri Dunan, S.E., M.M  
Rifandi Ritonga, S.H  
Desi Puspita Sari, S.E  
Roby Yuli Endra, S.Kom  
Tanto Lailam, S.H  
Ilyas Sadad, S.T., M.T

### **Publication and Documentation**

Ir. Indriati Agustina Gultom, M.M  
Monica Mutiara Tinambunan, S.I.Kom., M.I.Kom  
Noning Verawati, S.Sos  
Hesti, S.H  
Rifandi Ritonga, SH

Olivia Tjioener, S.E., M.M  
Violita, S.I.Kom

**Cosumption**

Dra. Yulfriwini, M.T  
Dra. Agustuti Handayani, M.M  
Susilowati, ST., MT  
Wiwin Susanty, S.Kom  
Reni Nursyanti, S.Kom  
DR.Dra. Ida Farida, M.Si

**Facility and Decoration**

Zainal Abidin, SE  
Ahyar Saleh, SE  
Eko Suhardiyanto  
Dina Ika Wahyuningsih, A.Md  
Wagino  
Sugimin

## **Table Of Content**

Organizing Committee.....	i
Table Of Content.....	v
<b>Keynote Speaker</b>	
1. Zinc-Air Battery – Powering Electric Vehicles to Smart Active Labels <b>Dr. Raihan Othman</b> .....	1
2. Enhancing Heat Transfer Using Nanofluids(abstract) <b>Prof. Ahmad Faris Ismail</b> .....	6
3. Rapid Prototyping and Evaluation for Green Manufacturing <b>RizaMuhida, Ph.D</b> .....	7
4. Indonesia’s Challenge to Combat Climate Change Using Clean Energy <b>Rudi Irawan, Ph.D</b> .....	12
5. Paraboloid-Ellipsoid Programming Problem <b>Prof.Dr. Ismail Bin Mohd</b> .....	15
6. Model Development of Children Under Mortality Rate With Group Method of Data Handling <b>Dr. IingLukman</b> .....	27
7. The Modified CW1 Algorithm For The Degree Restricted Minimum Spanning Tree Problem <b>Wamiliana, Ph.D</b> .....	36
8. The Fibre Optic Sensor in Biomedical Engineering and Biophotonics <b>Prof. TjinSweeChuan</b> .....	
<b>Speaker</b>	
1. Web-Based Service Optimization with JSON-RPC Platform in Java and PHP <b>WachyuHari Haji</b> .....	1
2. Trouble Ticketing System Based Standard ISO10002: 2004 To Improve Handling of Complaints Responsibility <b>Ahmad Cucus, Marzuki, AgusSukoco, Maria ShusantiFebrianti, Huda Budi Pamungkas</b> .....	6
3. Design of Warehouse Management Application Tool for Controlling The Supply Chain <b>Anita Ratnasari, Edi Kartawijaya</b> .....	10
4. Development Of Decision Related Engine Using Integration Of Genetic Algorithm And Text Mining <b>EvianaTjaturPutri, Mardalena, Asmah</b> .....	15
5. Implementing CBR on The College Rankings Based on Webometrics with EPSBED’s Data and Webometrics Knowledge	

	<b>Marzuki , Maria Shusanti F, Ahmad Cucus , AgusSukoco</b> .....	19
6.	Paypal Analysis as e-Payment in The e-Business Development <b>Nomi Br Sinulingga</b> .....	24
7.	Decision Support System for Determination of Employees Using Fuzzy Decision Tree <b>Sinawaty#1, YusniAmaliah</b> .....	28
8.	Analysis of Factors Influencing Consumer Behavior Bring Their Own Shopping Bag (Case Study Kecamatan Tembalang) <b>Aries Susanty, DyahIkaRinawati, FairuzZakiah</b> .....	33
9.	The Use of Edge Coloring Concept for Solving The Time Schedule Problem at Senior High School (Case Study at SMAN 9 Bandarlampung) <b>RahmanIndraKesuma, Wamiliana, MachudorYusman</b> .....	41
10.	Analysis Of Web-Education Based on ISO / IEC 9126-4 For The Measurement Of Quality Of Use <b>Marzuki, AgusSukoco, Ahmad Cucus, Maria ShusantiFebrianti, Lisa Devilia</b> .....	46
11.	The Used of Video Tracking for Developing a Simple Virtual Boxing <b>David HabsaraHareva, Martin</b> .....	55
12.	M-Government as Solutions for E-Government problems in Indonesia <b>Ahmad Cucus, Marzuki, AgusSukoco, Maria ShusantiFebrianti</b> .....	60
13.	Open Source ERP for SME <b>Tristiyanto</b> .....	65
14.	Improvement in Performance of WLAN 802.11e Using Genetic Fuzzy Admission Control <b>SetiyoBudiyanto</b> .....	70
15.	Cloud Computing: Current and Future <b>TaqwanThamrin, Marzuki, Reni Nursyanti, Andala Rama Putra</b> .....	75
16.	Implementing Information Technology, Information System And Its Application In Making The Blue Print for The One Stop Permission Services <b>Sri AgustinaRumapea, HumuntalRumapea</b> .....	80
17.	Integration System Of Web Based And SMS Gateway For Information System Of Tracer Study <b>EndykNoviyantono, Aidil</b> .....	86
18.	Fuzzy Logic Applied To Intelligent Traffic Light <b>EndykNoviyantono, Muhammad</b> .....	93
19.	Solving and Modeling Ken-ken Puzzleby Using Hybrid Genetics Algorithm <b>Olivia Johanna, Samuel Lukas, Kie Van IvankySaputra</b> .....	98
20.	GIS Habitat Based Models Spatial Analysis to Determine The Suitability Of Habitat For Elephants <b>AgusSukoco</b> .....	103

21. The Course Management System Workflow-Oriented to Control Admission and Academic Process <b>Usman Rizal, YuthsiAprilinda</b> .....	108
22. Fuzzy Graphs With Equal Fuzzy Domination And Independent Domination Numbers <b>A.Nagoorgani, P. Vijayalakshmi</b> .....	115
23. Solving Pixel Puzzle Using Rule-Based Techniques and Best First Search <b>Dina Stefani, Arnold Aribowo, Kie Van IvankySaputra, Samuel Lukas</b> .....	118
24. Capacity Needs for Public Safety Communication Use 700 MHz as Common Frequencyin Greater Jakarta Area <b>SetiyoBudiyanto</b> .....	125
25. Impact of Implementation Information Technology on Accounting <b>Sarjito Surya</b> .....	132
26. Document Management System Based on Paperless <b>WiwinSusanty, TaqwanThamrin, Erlangga, Ahmad Cucus</b> .....	135
27. Traceability Part For Meter A14C5 In PT Mecoindo Of The Measurement Of Quality Of Use <b>Suratman, WahyuHadiKristanto, AsepSuprianto, MuhamadFatchan, DendyPramudito</b> .....	139
28. Designing and Planning Tourism Park with Environment and Quality Vision and Information Technology-Based(Case Study: Natural Tourism Park Raman Dam) <b>Fritz A. Nuzir, AgusSukoco, Alex T</b> .....	149
29. Smart House Development Based On Microcontroller AVR-ATMEGA328 <b>Haryansyah, Fitriansyah Ahmad, Hadriansa</b> .....	157
30. Analyze The Characteristic of Rainfall and Intensity Duration Frequency (IDF) Curve at Lampung Province <b>Susilowati</b> .....	161
31. The Research of Four Sugarcane Variety ( <i>Saccharum officinarum</i> ) as The Raw Materials of Bioethanol Production in Negara Bumi Ilir Lampung <b>M.C.Tri Atmodjo, Agus Eko T, Sigit Setiadi, Nurul Rusdi, Ngatinem JP, Rina, Melina, Agus Himawan</b> .....	174
32. Design an Inverter for Residential Wind Generator <b>Riza Muhida, Afzeri Tamsir, Rudi Irawan, Ahmad Firdaus A. Zaidi</b> .....	177
33. The Research of Two Sugarcane Variety ( <i>Saccharum officinarum</i> ) as The Raw Materials of Bioethanol Production in Negara Bumi Ilir - Lampung <b>M.C. Tri Atmodjo, Agus Eko T., Sigit Setiadi, Nurul Rusdi, Ngatinem JP, Rina, Melina, Agus H.</b> .....	182
34. Design of Plate Cutting Machine For Cane Cutter ( <i>Saccharum Oficinarum</i> ) Use Asetilin Gas <b>M,C, Tri Atmodjo, Tumpal O.R, Sigit D.Puspito</b> .....	186



35.	Behaviour of Sandwiched Concrete Beam under Flexural Loading <b>Firdaus, Rosidawani</b> .....	191
36.	Diesel Particulate Matter Distribution of DI Diesel Engine Using Tire Disposal Fuel <b>Agung Sudrajad</b> .....	196
37.	Microstructure Alterations of Ti-6Al-4V ELI during Turning by Using Tungsten Carbide Inserts under Dry Cutting Condition Ibrahim, G.A. Arinal, H, Zulhanif, Haron, C.H.C .....	200
38.	Validation Study of Simplified Soil Mechanics Method Design with Kentledge Pile Loading Test of Bored Pile Lilies Widodojoko .....	204
39.	Performance Assessment Tool for Transportation Infrastructure and Urban Development for Tourism Diana Lisa .....	211
40.	Earthquake Resistant House Building Structure Ardiansyah .....	221

# Traceability Part for Meter A14C5 in PT Mecoindo of the Measurement of Quality of Use

Suratman<sup>#1</sup>, Wahyu Hadi Kristanto<sup>#2</sup>, Asep Suprianto<sup>#3</sup>, Muhamad Fatchan<sup>#4</sup>, Dendy Pramudito<sup>#5</sup>

<sup>#1,2,3,4,5</sup> STT Pelita Bangsa

Jl. Inspeksi Kalimalang, Tegal Danas, Bekasi, Wesr Java, Indonesia

<sup>1</sup>suratman8@gmail.com,

<sup>2</sup>asankhan.prashan@gmail.com

<sup>3</sup>Asep.Suprianto@Itron.com

<sup>4</sup>wahyu\_hk.piskel@yahoo.co.id

<sup>5</sup>ftn\_dus76@yahoo.com

**Abstract**— With the expansion of global trade, computerization and communications, plain language descriptions of products and services need to be replaced by identification and product tracing systems that are usable in all trade and industry sectors worldwide. Product traceability is the process of maintaining records of all materials and parts from purchasing to finished goods where a unique number identify a part, batch, or a finished product.

Traceability provides the ability to identify and track a product or a component to its point of origin. The point of origin may be a particular lot or batch, production line and time frame, field, or supplier. Product traceability is very important to reliability. If a particular lot of a critical component is found to be defective after being used in product that is already sold, traceability provides a means of identifying the units for recall. Some products (e.g. aircraft components, fresh produce, meat) require complete traceability. Here are some of the benefits and solutions provided with product identification and tracing: Procedures for identifying and tracing the product during all stages of production, delivery & installation; Requires knowing what parts comprise the product, their specification, their status, etc; Requires knowing the exact content of products that have been delivered to each customer so that the right customer service can be provided; Helps to satisfy “Process Control”.

In this paper we are going to accent on EAN UCC numbering system where EAN stands for European Article Numbering and UCC stands for Uniform Code Council. EAN/UCC numbers provide unique and unambiguous identification for worldwide recognition and can improve the efficiency and exchanging information between supply chain participants.

Parts Traceability Information System used by PT. Mecoin do to record a part-part starting from the arrival until assembled into products used by each part will kWh meter. So that in a product can be traced GRS kWh meter that is used by each part. As for the concept of the approach taken is an object-oriented approach is to view the problem by using a model - a model that is organized (which combines the issues surrounding the concept of data structure and behavior of an entity). In this approach, the software organization is a collection of discrete objects that work together, communicate and interact to a certain target.

**Keyword** – *quality of use*

## I. INTRODUCTION

Current technological developments are fast enough, the one with the other countries can interact easily, quickly and efficiently.

They can communicate, exchange information quickly via the Internet, telephone and other media. The many advances in both the private sector or the government can work together for mutually beneficial purposes. PT. Mecoindo cooperation with Chasseneuil (electrical measuring instrument manufacturer in France) in the manufacture of electrical measuring instruments, named kWh Meter A14C5

High production is done, then the product is sent to Chasseneuil, but sometimes there are some products are not as expected, for example, the product does not function properly or may die. This will lead to complaints from the Customer to the PT. Mecoindo. Having analyzed the products had been rejected, there was one part such as a death PCBA. PCBA who die are then tracked their data need to be produced in conditions of Supplier. The data on the part needs to be tracked in order to immediately know the problem so it can be done to improve quality. Thus the authors are interested in doing research on part traceability system in order to perform the tracking of parts that make up a product.

A kWh meter sometimes produced a double, a product called a double kWh meter can be seen from the customer serial number or serial number or serial number on the two units of kWh meter, if the two kWh meters of the same serial number. Human Error else is writing the serial number does not correspond Order Form (OF). Of the documents from the engineering department as a basis or guide in the production process. Such errors can be fatal if the production until the number in the thousands and sent to Customer.

The production process in the production outposts in line A14. Each - each post has a process and different functions., As well as human error, which was named one of the postal zip configuration of negligence which continue the process

to the next post, but have not been processed in the post. The process can not be overlooked is detected automatically by the machine. Configuring the process record serial number into memory kWh meter.

Good Received System (GRS) is given for each part by the arrival of the consignee. Every part that goes into the production line will be recorded GRSnya. Current manual recording, a lot of paper used to record any changes in GRS. This gives rise to waste paper. In search of a year datapun when it will be difficult because they have to sort through the pile of paper. Based on some of the problems above, the authors are interested in doing research on Parts Traceability System in PT. Mecoindo according to research the title the author gave.

## II. MODEL, ANALYSIS, DESIGN DAN IMPLEMENTATION

### 2.1 Reserch of Model

Research can be grouped into several types of research, for example:

- a. **Qualitative research** (including historical and descriptive research) is the research that does not use mathematical models, statistical or computer. The research process begins by establishing the basic assumptions and rules of thinking that will be used in the study. Assumptions and rules are then applied to think systematically in collecting and processing data to provide explanations and arguments. In a qualitative study of information collected and processed should remain objective and not influenced by the opinions of researchers themselves.
- b. **Qualitative research are widely applied** in the study of historical or descriptive.  
Historical research to apply the scientific method of solving a historical approach. Research process includes the collection and interpretation of phenomena occurring in the past to find a generalization that is useful to understand, predict or control the phenomenon or group of phenomena. Research of this type are sometimes referred to as documentary research for references used in this study are generally in the form of the document. Historical research can be comparative, ie, showing the relationship of some kind of phenomenon by showing similarities and differences; bibliographic, which provides a comprehensive picture of the opinions or thinking of experts in a particular field to collect the documents on the subject: or biographical, which gives broad understanding of a subject, the nature and character of the subject individual, the effect was received by the subjects during the formation of the subject's personality and value to the development of an aspect of life.
- c. **Descriptive research is the study** of phenomena that occur in the present. The process of collection and compilation of data, as well as analysis and interpretation of these data. Descriptive studies can be comparative to compare similarities and differences of certain phenomena; qualitative analytical to explain the

phenomenon with the rules of scientific thinking systematically applied without the use of quantitative models, or by holding a normative classification, valuation standards, norms, relationships and the position of an element with another elemen.

- d. **Theoretical research** is research that only uses reasoning alone to obtain the conclusion of the study. The research process can be started by setting the assumptions and logic thinking. Of the assumptions and logic were formulated presumptions (conjecture). Presumption of a thesis proved or explained by systematically applying the assumptions and logic. One of the assumptions and logic of the application form to form a concept to solve the problem is to establish a quantitative model. In some theoretical studies are not conducted the data collection. Experimental research is research done by creating phenomena in controlled conditions. This study aims to discover causal relationships and the influence of these factors on certain conditions. In its simplest form, this experimental approach seeks to explain, control and predict phenomena as precisely as possible. In many experimental studies used a quantitative model.
- e. **Engineering research (including research software)** is an applied science research into a plan to get the performance in accordance with specified requirements. The design is a synthesis of the design elements combined with the scientific method became a model that meets certain specifications. The study aimed to prove that the design meets the specifications defined. The study begins with determining the design specifications that meet defined specifications, choose the best alternative, and prove that the chosen design to meet the requirements specified in the efficiency, effective and low cost. Research can be classified as computer software engineering research.

### 2.2 Analysis Methods

- a. Method of "Trial and Error" This method is carried out by trials or testing-testing-related research conducted at the computer. Methods escriptive is a method in the research st
- b. atus of a group of people, an object, a system of thought or a class of events in the present in order to create a picture or painting in a systematic, timely and reliable information about the facts - the facts are analyzed, and the nature - the nature of related between the phenomenon under investigation. (Moh.Nazir, Ph.D, 1983).

### 2.3 Data Collection Techniques

- a. Observation (field and reseach)  
Direct observation of the system running, and analyzing and designing new systems to support and update existing systems.
- b. Interview  
Conduct interviews or question and answer directly to

the employee or the production company involved with the issues under study.

c. Browsing.

Do a search of data - data that support for research through the Internet by visiting the web page a lot in it.

d. Studies Library (Library Research Method

This technique is done by searching the literature related to the research topic, the traceability of parts, with the programming language Visual Basic 6.0

2.4 Desain Identification

a. Inditification Product dan Traceability Function Tool

Product Identification and Traceability Functions:

- User can identify a product uniquely in terms of product identification, manufacturing order number, process order number, lot number, and inspection order number in all stages of manufacturing. It also links each component element, whether material, process, measuring gauge or personnel to any related activities for final output or traceability.
- Unique product identification and lot number.
- Association with applicable drawings, specifications, revisions and quality records.
- Traceability to personnel performing quality activities.
- Traceability to measuring instruments, gages and tools that are used during the production process

Item numbering is a system of identifying products by giving each one a unique number. In the table bellow paper we are going to describe the EAN UCC bar code numbering system. The system provides for global uniqueness and overcomes problems in confusion, duplication and misinterpretation because all of its users follow the same coding rules.

b. Barcode Steps

TABLE I  
BARCODE STEPS

<b>Coding Requirement</b>	Define What will be Encoded and in What Order At this early stage you must decide what information needs to be put into the bar code. Often, a mandate references guidelines that have been reviewed and approved by a specific industry or standards setting organization.
<b>Machine Readable Language</b>	In Bar Code Language this is called a Symbology A bar code is a graphic representation for numbers or alphabetic characters. Typical bar code images are made up of a pattern of lines and spaces or light and dark areas. The graphic symbols represent data characters as well as some control characters.
<b>Encode Data</b>	Create the Bar Code Bar code symbols may be produced on demand at the production facility or you can purchase pre-printed bar code labels from a printing bureau that has bar code experience.
<b>Quality Control</b>	Verify the Data Bar code verification is the bridge between creating the bar code image and successful scan accuracy rates. A verifier will inspect and report on bar/space widths or light and dark areas and check other characteristics of the image for scanning ease and accuracy.

<b>Apply Markings</b>	Directly Mark Items or Apply Preprinted Labels Bar code symbols may be produced in a variety of ways: by direct marking, as with laser etching or with ink jet printing; or, more commonly by imaging or printing the bar code symbol onto a separate label and then applying the label to the product.
<b>Decode Data</b>	Scan the Bar Code This function is performed by a scanner and an interface controller called a decoder. The light source in the scanner reflects the information in the bar code by "translating" dark and light images into the appropriate data.
<b>Transmit Data</b>	Communicate the Decoded Data to the Computer Data communications is the key link in implementing an automatic identification system. Decoded data is transmitted to the computer.
<b>Data Usage</b>	Use the Data The host system receives the information and uses it for a different purpose. This may be: inventory control, manufacturing process control, shipping & receiving, quality control, automated re-ordering, electronic commerce, etc.

c. Fresh Produce Traceability

Traceability requires the identification of all physical entities (locations) where fresh produce originates from and where it is packed and stored. These may include but are not limited to fields, growers, packers, carriers, wholesalers and retailers.

A system for identifying and tracing produce is needed so that sub-standard or unsafe produce can be recalled. It also enables the cause of problems to be identified and their recurrence prevented. The essential requirements for an effective system are:

- Each batch of product must be clearly marked.
- A record must be kept of the batch ID and the destination details.
- Records of operations critical to food safety and quality must be maintained.

The following table shows how product identification methods and records combine to form an effective system for product identification and traceability linking the stages of growing, packing and delivery to retailers

d. Fresh produce supply chain traceability model

TABLE II  
TRACKING

	Tracking →				
	Grower	Pack house	Batch	Supplier	MH
<i>Product Identification Method</i>	Block ID sign placed in a prominent position	Grower/block/variety ID on each bin or container or recorded on a card attached to each pallet of containers	Batch ID on each package	Product ID on each package or on a card attached to each pallet	Packer ID on each package or on a card attached to each pallet
<i>Traceability Records</i>	Farm plan map Spray diary, farm operations diary or paddock/block record	Record of receipt Post-harvest chemical Cooling log Packing and delivery record	Consignment note Delivery advice	Invoice, Delivery Slip	Invoice, Delivery Slip
	Grower	Batch	Pack house	Supplier	MH
	← Tracing				

### e. Basic Concepts of Object-Based System Design.

Object-oriented approach is the perspective problem by using a model - a model that is organized (which combines the issues surrounding the concept of data structure and behavior of an entity). In this approach, the software organization is a collection of discrete objects that work together, communicate and interact to a certain target.

#### • Class

Class is a description of one or more objects with a set of attributes and service uniforms, including a description of the creation of new objects in the class.

Characteristics - the characteristics of the class are as follows:

#### ✓ **Tangibility**

Namely whether there are classes that present the physical entities or abstract information presented

#### ✓ **Inclusiveness**

Namely whether the atomic class (does not contain the class - the other class) or class is the aggregate (containing at least one object in it).

#### ✓ **Sequentially**

Namely whether concurrent (have a lot of control flow) or sequen (controlled external resources).

#### ✓ **Persistence**

Persistence properties are divided by class as follows:

- Transient, which is created and removed during operation of the program. Temporary, that is created during the surgery and removed once the program ends.
- Permanent, which is stored in the Database.

#### ✓ **Integrity**

Namely whether the class can be changed (guarded its resources from external influences) or impose a class that is guarded resource control object

#### **Class have**

- Name Class has a name that distinguishes it from the class - the other class.
- Attributes; Properties that describe a class named range values can have instant class.
- Operations / Methods; Operation is the implementation of services that can be requested from an object.
- Responsibilities; Responsibility is the contact / liability class that contains a number of attributes and operations is an infestation of responsibility to which it aspires to be implemented.

### f. Object

Fumbaugh defines the object as a concept, abstraction or something with a clear deadline for the problem at hand. Thus there are two uses of objects, namely;

- To improve the understanding of the real world.
- To provide a practical basis for computer implementation.

Object has the following properties:

- ✓ State, State objects include all the properties of objects (usually static) plus the value - the value of the property at the time (usually dynamic).

- ✓ Conduct, That is how the objects - objects to react and act in change - change of status and is determined by the set of all or some operations can be performed by the object itself.
- ✓ The identity of That is the object properties that distinguish it from all other objects.

### 2.4 System Design Using the Method Unified Modeling Language (UML).

UML is a language that determines, visualization, construction and documenting the artifacts of software systems, to model the business and other nonsoftware system. Rational Rose is a software that has a device - a visual modeling tools to build a solution in software engineering and business modeling. Rational Rose software issued by a company called Rational Software, a company that sparked the idea for the formation of a consortium of companies - companies that use UML as a standard modeling language in the company. (Suhendar, and Gunadi, 2002).

The main purpose of UML are :

- ✓ Provides a ready-made model with expressive visual modeling language to develop and exchange models with simple and commonly understood.
- ✓ Provide modeling language that is free from various programming languages and process engineering.
- ✓ Integrating practices - best practices contained in the modeling.

Elements - elements that are commonly used in modeling business processes in UML, namely:

#### a. Actor

Actor describes the use of software applications (the user). Actor helps give a clear picture of what to do with software applications.

Actor in UML are denoted as shown below.

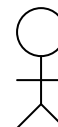

Fig 1. Actor

#### b. Use Case.

Use case describes the behavior of software applications, including the interaction between the actor with the software application.

In general usecase is:

- ✓ The pattern of behavior of software applications.
- ✓ A sequence of related transactions and performed by an actor with a software application..
- ✓ System or objects that provide something of value to the actor.

Based on your exit in the actor, usecase is divided into two, namely:

Concrete usecase, which created direct usecase for the purposes of actor. Actor can view and take the initiative against him.

Abstract usecase, the usecase that never stand alone. Usecase is always included in (include), or expanded from the (extended) or formulation (generalize) from other usecase.

Graphically, the usecase is denoted as follows:



Fig 2. Use Case

Prior to model analysis, we should understand well the class - a class in the analysis. Class - the class are:

**c. Boundary**

Is a class that models the interaction between one or more actors in the system. Boundary can be:

- ✓ User Interface which is a means of communication between the system with the user, such as a window (window) in the Graphical User Interface (GUI).
- ✓ System Interface which is a means of communication between systems with other information systems, such as communication protocol.
- ✓ Device Interface which is a means of communication between the system with the device (equipment), such as printers, sensors.

Boundary notated in UML with the notation:

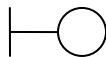

Fig 3. Boundary

**d. Control**

Control is used to model "behavioral set", specific to one or several usecase only. Control is not influenced by the changes around them. These elements make the use or content of the element entity and is usually installed with the element boundary element entity.



Fig 4. Control

**e. Entity**

Entity modeling the information that must be stored by the system. Entity shows the data structure of a system. Entity is usually passive and still. The main responsibility of this element is to store and organize information from the system.

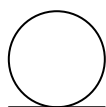

Fig 5. Entity

**III. ANALYSIS OF THE CURRENT SYSTEM**

Production is running at PT. Actaris Mecoido involving several entities such as Customer, Sales Mecoido, Technical Mecoido, PPIC and the Production and Quality. As for things that are done each section are as follows:

**A. Customer.**

- PO (Purchase Order) on Sales Mecoido Receive product of Order that was made.
- Sales, Receive PO from the customer and given to the Technical.
- Technical, Receive PO and PO from Sales Order modified in the form of Form (OF) Provide OF the PPIC for given target and approved Receive an OF of PPIC is already in the approved Provide OF goto Production.
- PPIC  
Receive an OF of the Technical Provide targeted delivery of goods Perform stock control of production materials Setting up the goods according to production needs Provide OF which has been given a target gets technical.
- Production  
Receive an OF of the Technical

**B. Activity Diagram The Current System**

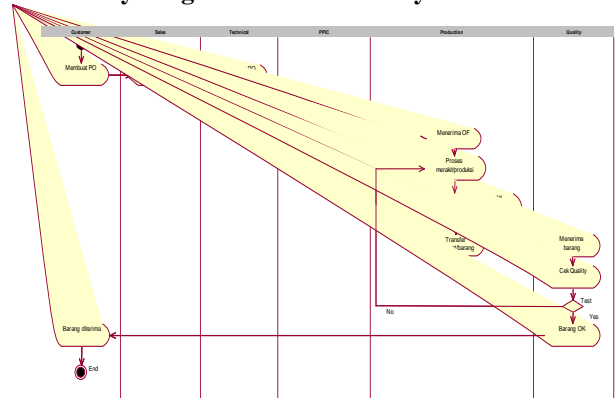

Fig 6. Activity Diagram the Current System

**C. Activity Diagram of Proposed System**

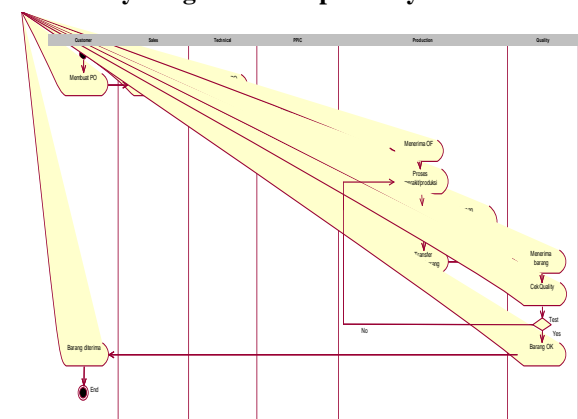

Fig 7. Activity Diagram of Proposed System

Part Traceability System is a system that is proposed as a solution to solving the problem. Given this system of production problems can be resolved. This system will record the arrival to be part of a product. Part is already a product it will be known GRS. GRS is a unique code on the arrival of a part in Mecoindo or lot number can be called arrival.

Part Traceability system will be used to assist the production if they want to know the parts are arranged parts. Part Traceability systems must be able to do pengecekan as Quality control of the product being manufactured. Weaknesses mentioned above is the thing to do repairs.

With Traceability System Parts that have been mentioned problems can be resolved. As for things that are done each section are as follows:

#### A. Customer.

1. PO (Purchase Order) on Sales Mecoindo. Receive product of Order that was made.
2. Sales.Receive PO from the customer and given to the Technical.
3. Technical.Receive PO from Sales and PO is converted in the form of OF (Order Form) Provide OF the PPIC for given target and approved.Receive an OF of PPIC is already in the approved. Provide OF goto Production.
4. PPIC.Receive an OF of the Technical Provide targeted delivery of goodsPerform stock control of production materials Setting up the goods according to production needs Provide OF which has been given a target gets technical..
5. Quality.Perform pengecekan against part that comes in the PT. Mecoindo. Incoming Quality parts are parts that do the sampling. Sampling is done to represent the overall quality of parts that come up. If the results are good then the part is otherwise accept or OK. Conversely, if the result is not well expressed Not Good (NG) or Reject. Part of OK will be given to production for production meter.
6. Production.Receive an OF of the TechnicalPerform the assembly (Assem bly) To record the application system When the process is complete then performed for the Production of Quality Checks, if there is defective production of the assembly will be done again if it is not production ready to be sent to the Customer. Send the Order that was ordered by the Customer. Parts Traceability system will be implemented into an application that in fact can help in the production activities of daily performance. The system is designed to be developed for the purpose of all production line at PT. Mecoindo. The system is designed to be melancak production has been carried out starting from the production data, which make up part-part, part that has a history of the arrival of the GRS and the date of production in the supplier, up to automatically control

the configuration process or process prior to packing, the meter not in accordance with the Order Form as well for double the serial number and no manual records used for parts production.

#### IV. IMPELENTATION SYSTEM

In designing this system the author uses a method in Object Oriented Analysis Design (OOAD) is a UML method. The author considers UML notation is rich - it has a lot of diagram notation, where each - each diagram has a different point of view - different. But the authors do not use this design as a whole that there are diagrams in UML, because with some diagrams alone will represent the system to be designed by the author.

In this design the authors divide into two ways, namely identifikas needs of the system from the viewpoint of the user / actor and the identification of needs from the standpoint of logical systems in an effort to find as many possible variables in order to achieve maximum system design.

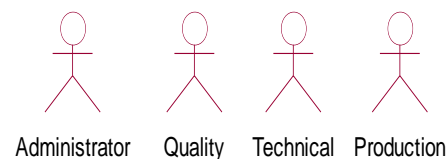

Fig 8. Actor Application System

1. Usecase diagram.
  - Of an actor going in their wake - each with their system - each process contained in it. The usecase is identified on each - each system are:
    1. *Administrator*
      - *Usecase Input Users*
      - *Usecase Edit Users*
      - *Usecase Delete Users*
      - *Usecase Input Employees*
      - *Usecase Edit Employees*
      - *Usecase Delete Employees*
    2. *Quality*
      - *Usecase Input Suppliers*
      - *Usecase Edit Suppliers*
      - *Usecase Delete Suppliers*
      - *Usecase Input Parts*
      - *Usecase Edit Parts*
      - *Usecase Delete Parts*
      - *Usecase Input Incoming Parts*
      - *Usecase Edit Incoming Parts*
      - *Usecase Delete Incoming Parts*
      - *Usecase Input Incoming Checking*
      - *Usecase Edit Incoming Checking*
      - *Usecase Delete Incoming Checking*

3. Technical

- Usecase Input Meter
- Usecase Edit Meter
- Usecase Delete Meter
- Usecase Input Order Form (OF)
- Usecase Edit Order Form (OF)
- Usecase Delete Order Form (OF)

4. Production

- Usecase Input NOBC
- Usecase Edit NOBC
- Usecase Delete NOBC
- Usecase Input Production
- Usecase Edit Production
- Usecase Delete Production
- Usecase Input Packing
- Usecase Edit Packing
- Usecase Delete Packing

2. Usecase Diagram Picture

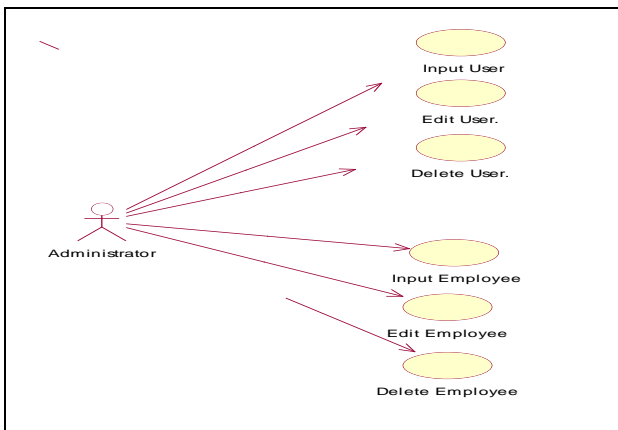

Fig 9. Use Case Diagram Input User

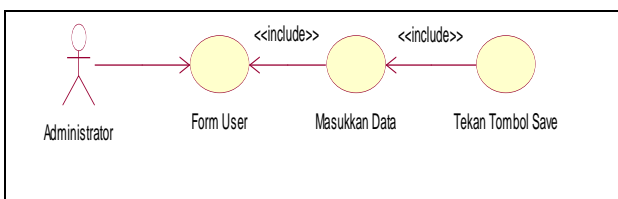

Fig 10. Use Case Diagram Edit User

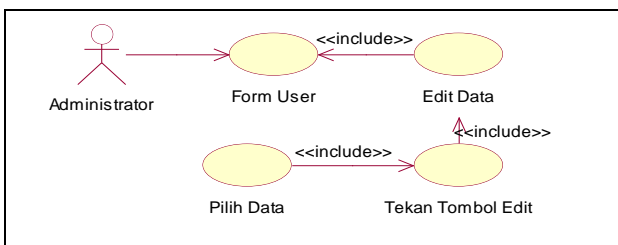

Fig 11. Use Case Diagram Delete User

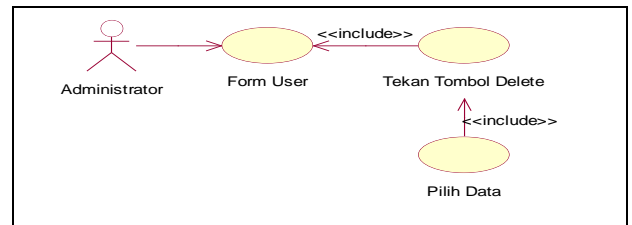

Fig 12. Diagram Input Employee

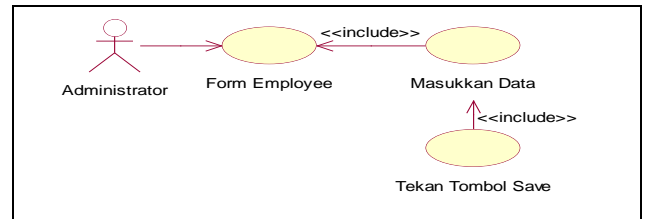

Fig 13. Diagram Input Supplier

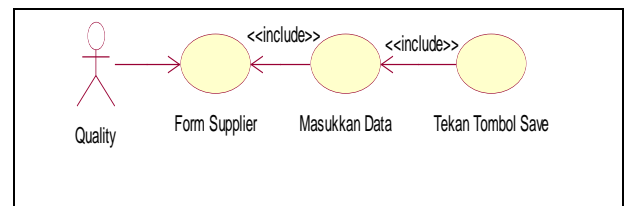

Fig 14. Use Case Input Part

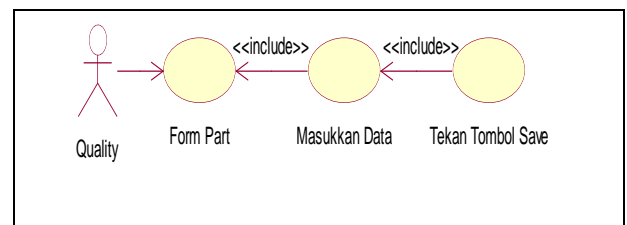

Fig 15. Use case Quality Checking

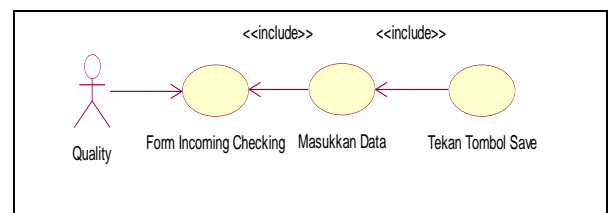

Fig 16. Use Case Teknik Edit OF

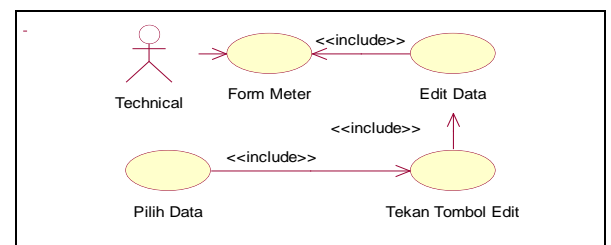

Fig 17. Use Cse Input NOBC



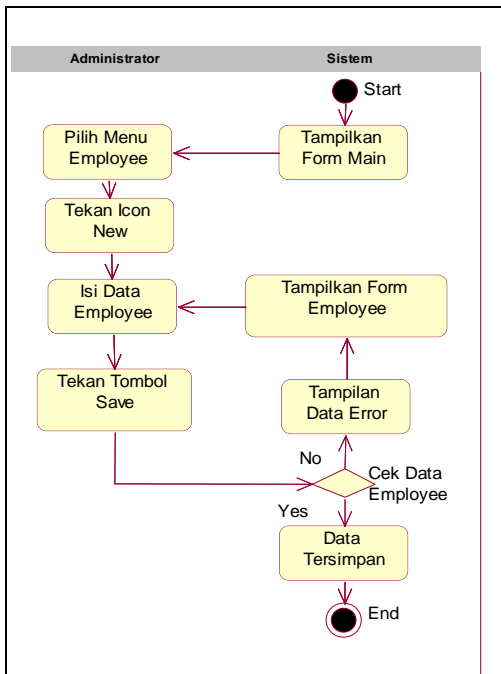

Fig 18. Use Case Input Production

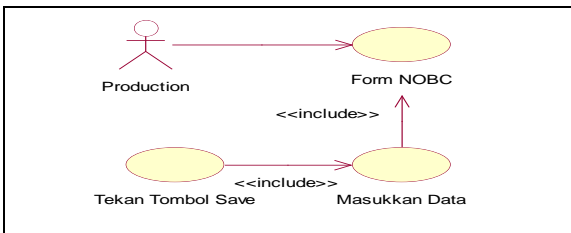

Fig 19. Use case Input Packing

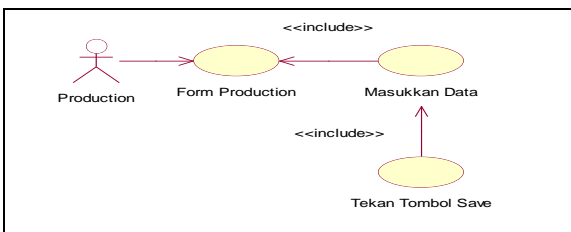

Fig 20. Use Case Activity Input User

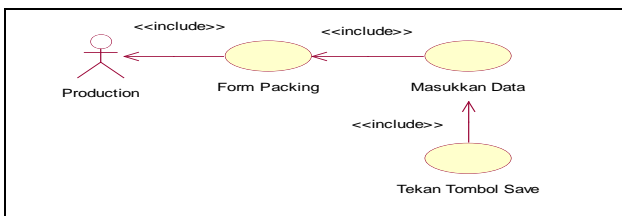

Fig 21. Activity Input Employee

which the actor will interact with the system. The relationship can be described by the activity diagram as shown below :

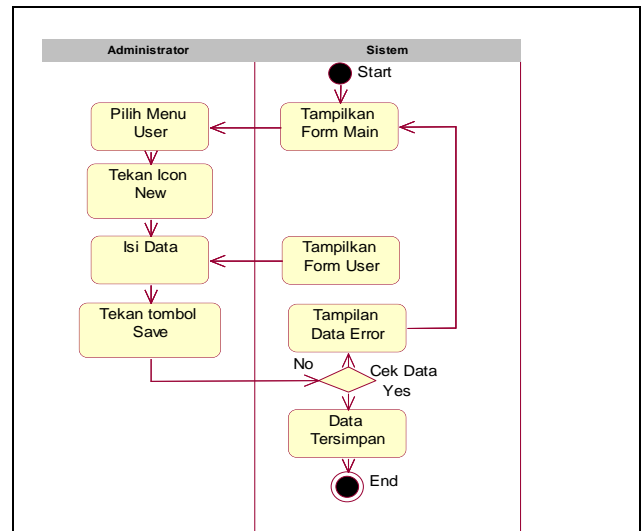

Fig 22. Use Case Activity Input Suppliers

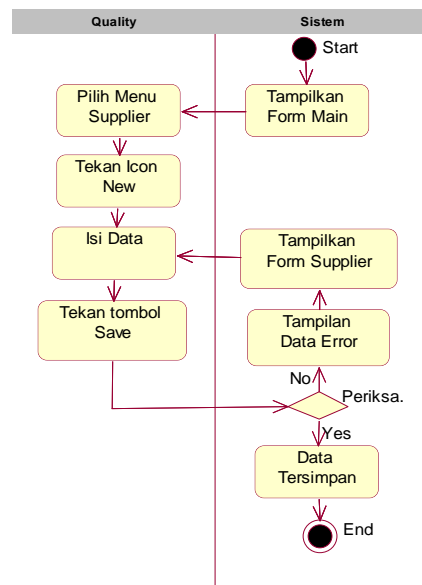

Fig 23. Use Case activity Input part

❖ Activity diagram.

Activity diagrams describe interactions that occur between the user with the system on each - each usecase. The function diagram illustrates the sequence of activity - an activity in

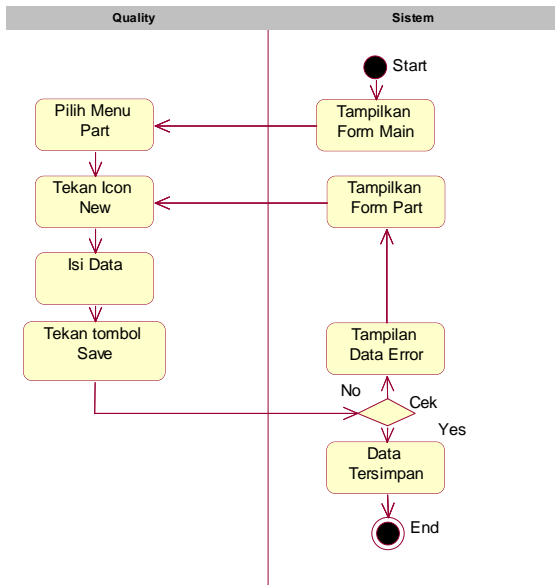

Fig 23. Use Case Activity Input Meter

5. Achievement Satisfaction

a. Material handling performance for Questioner

TABLE III  
 SATISFICATION PERFORMANCE

No	Person	Resp. Satisfied	Resp. Not Satisfied
1	30	29	1

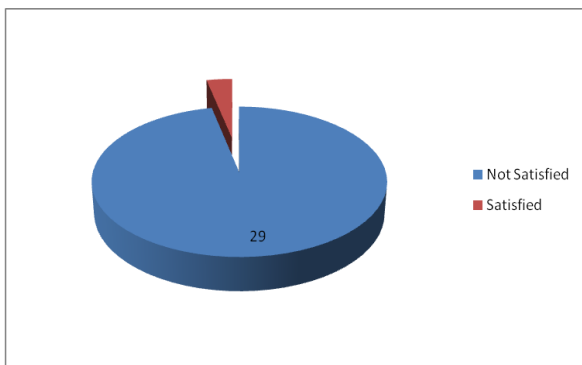

b. Teknik Performance

TABLE IV  
 SATISFICATION PERFORMANCE

No	Person	Resp. Satisfied	Resp. Not Satisfied
1	10	10	0

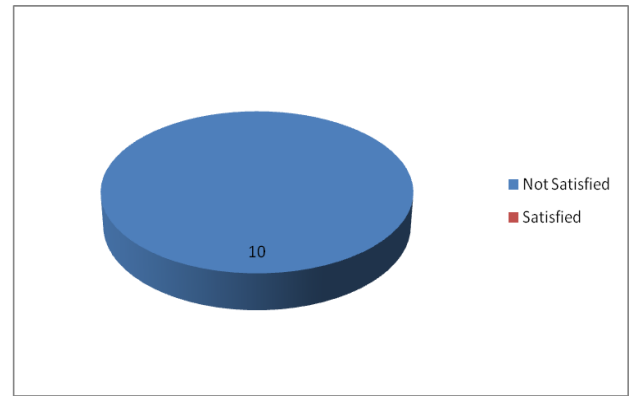

c. Quality Performance

TABLE IV  
 QUALITY PERFORMANCE

No	Person	Resp. Satisfied	Resp. Not Satisfied
1	15	24	1

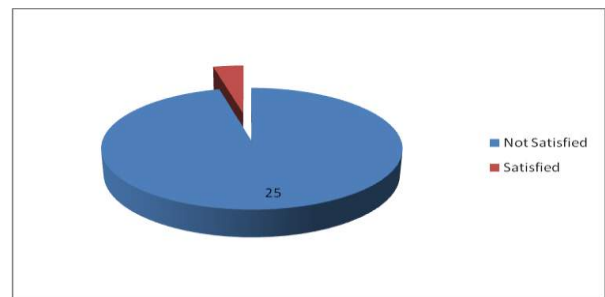

d. Customer Survei

TABLE IV  
 CUSTOMER SURVEY

No	Person	Resp. Satisfied	Resp. Not Satisfied
1	30	29	1

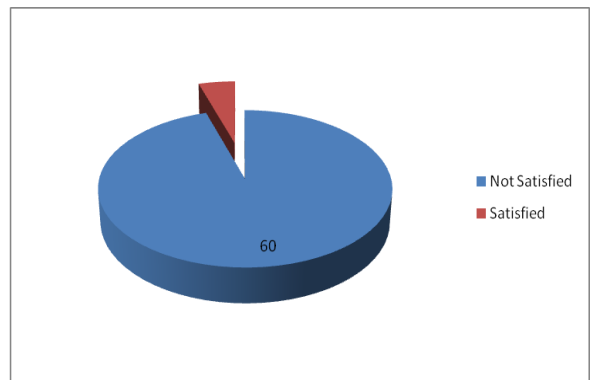

REFERENCES

- [1] Budiharto, Widodo, S. Si. Of 2002. Database Applications with SQL Server 2000 & Visual Basic 6.0. PT Elex Media Komputindo, Scholastic, Jakarta.
- [2] Indriyanna, Beautiful and Nugroho. 2007 Retailing Information Systems with SQL Server and VB 6.0. . PT Elex Media Komputindo, Scholastic, Jakarta.
- [3] Michael Halvorson. 2002., Microsoft Visual Basic 6.0 Professional Step by Step. PT. Elex Media, Jakarta
- [4] Prasetyo, Didik Dwi. , 2003. Database Processing with Visual Basic. Net and MySQL Server. PT Elex Media Komputindo, Scholastic, Jakarta.
- [5] Jogiyanto H. M. .1989. Analysis and Design of Information Systems. Andi Yogyakarta, Yogyakarta
- [6] Raymond Mc Leod, Jr. , 2004. Management Information Systems. PT Prenhallindo, Jakarta.
- [7] Bambang Hariyanto, Ir., MT (2004). "Object-Oriented System Engineering. Information Technology Bandung, Bandung
- [8] A. Suhendar, S.Si and Hariman Gunadi, S.Si., MT. , 2005. Visual Modeling Using UML and Rational Rose. Informatics, Bandung, Bandung.

Hosted By :  
Faculty of Engineering and Faculty of Computer Science  
Universitas Bandar Lampung (UBL)

